

| |
|------|
| ue |
| 30 |
| 60 |
| 6 |
| 00 |
| 00 |
| 50 |
| +150 |

| |
|-----|
| Max |
| |
| |

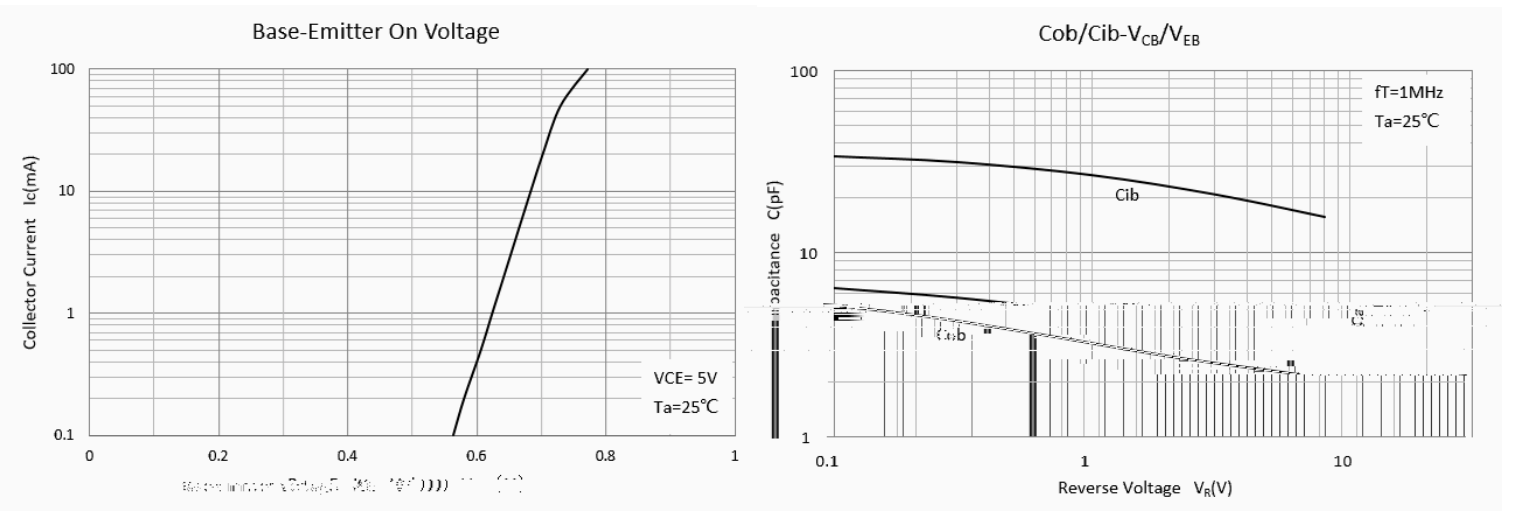

Characteristics (Typical)

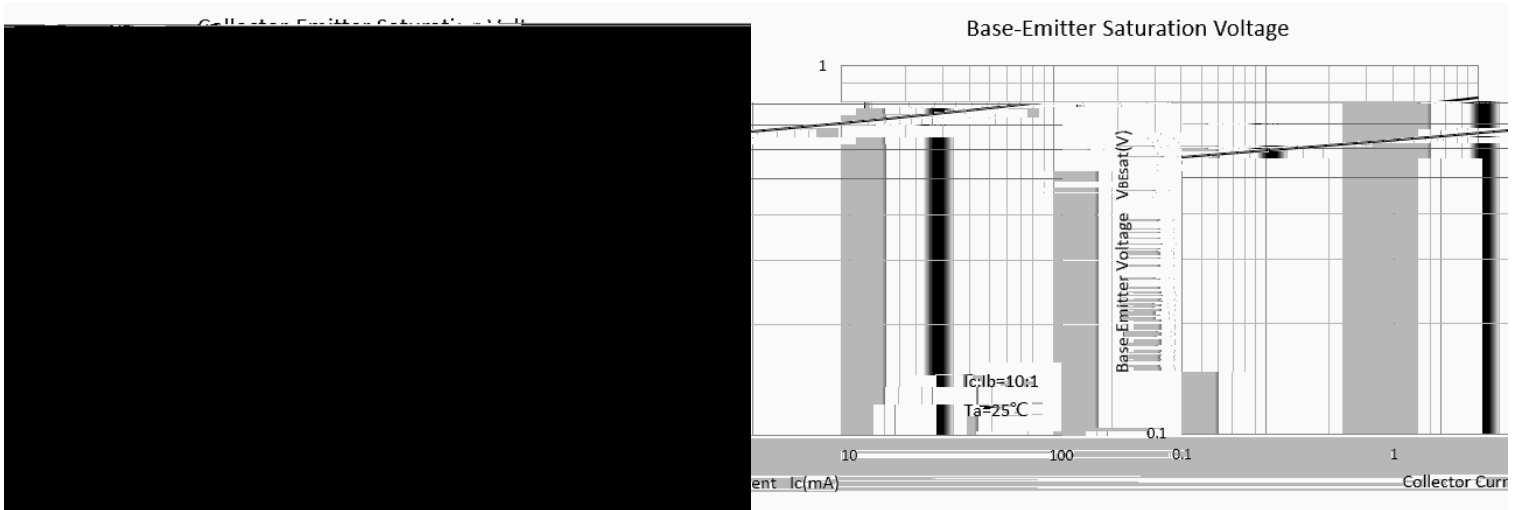
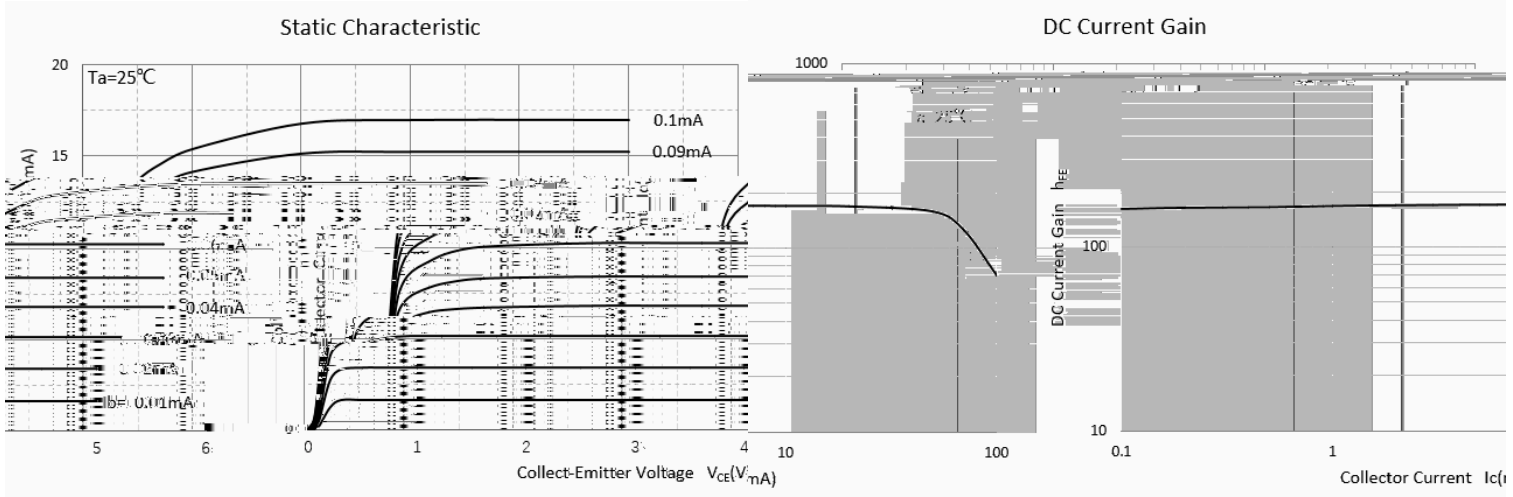



SOT-363 Package Outline Dimensions

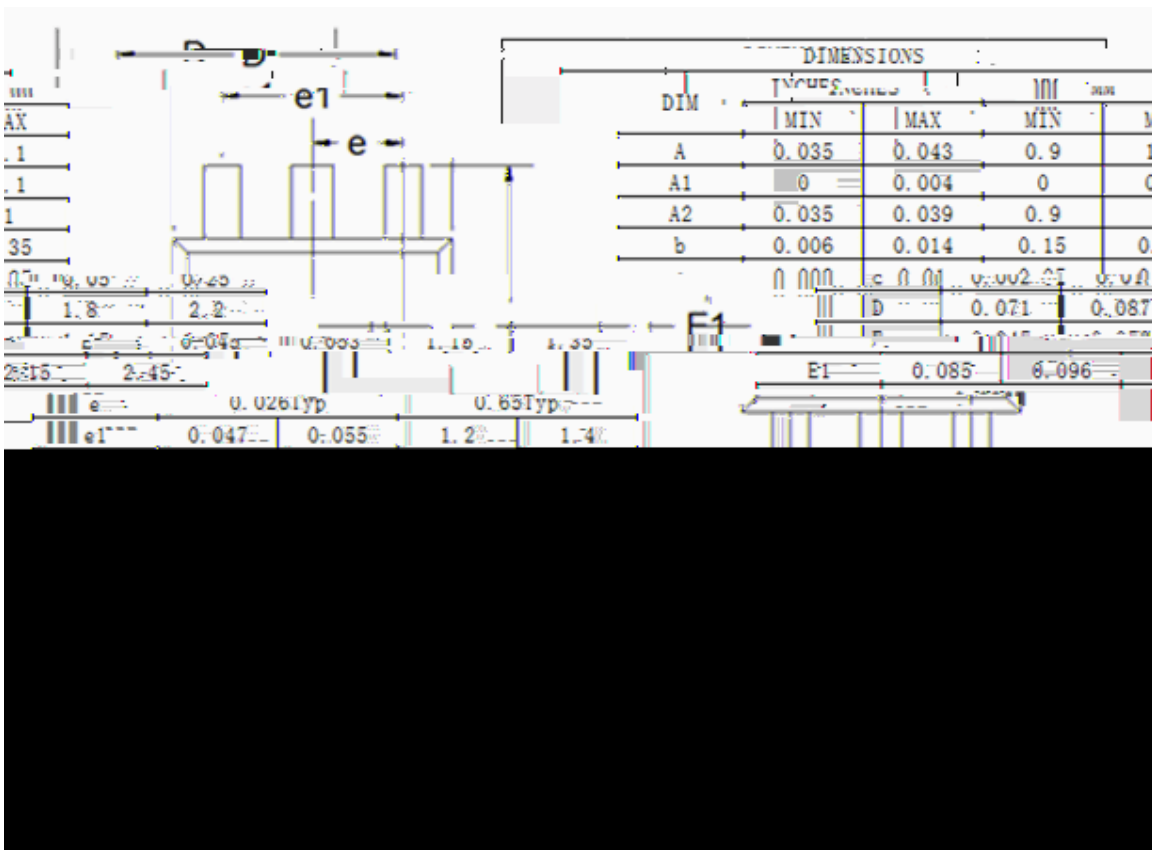

SOT-363 Soldering Footprint

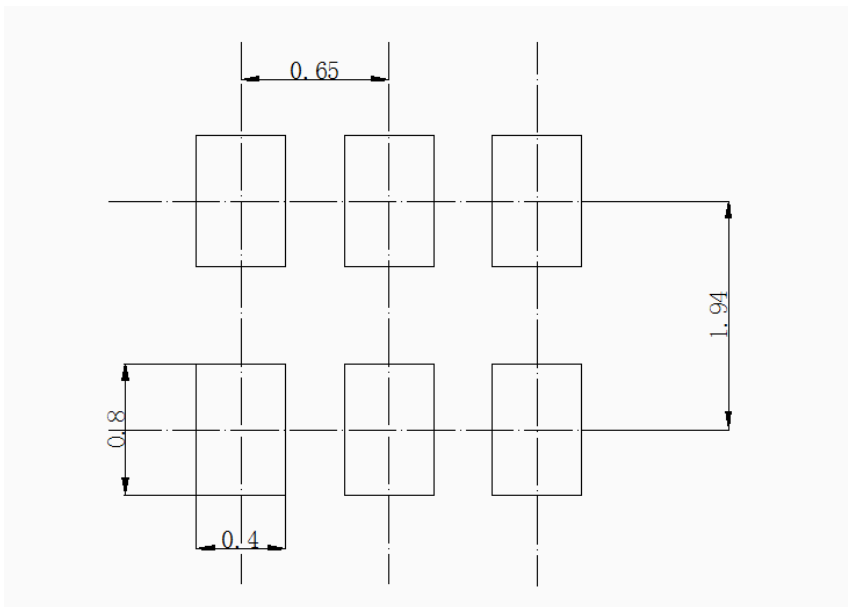

Unit mm

