



YJL10P02AL

P-Channel Enhancement Mode Field Effect Transistor

Product Summary

General Description

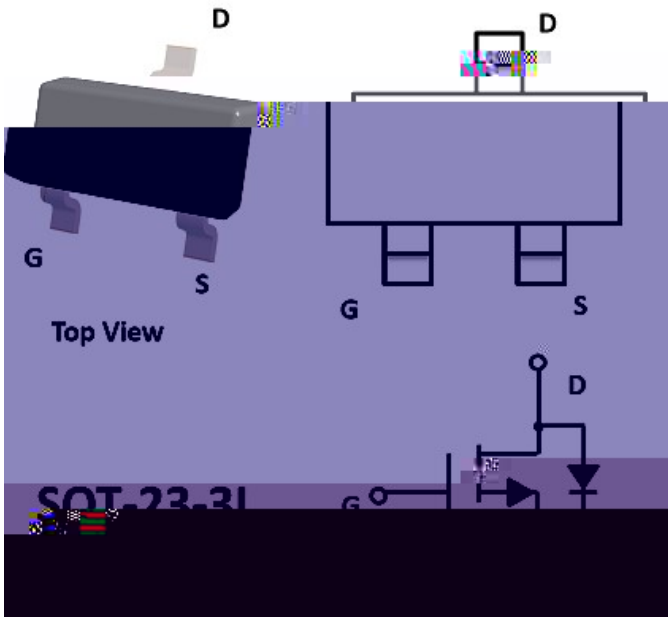



YJL10P02AL

Electrical Characteristics

Parameter	Symbol	Conditions	Min	Typ	Max	Units
Static Parameter						
Dynamic Parameters						



Typical Performance Characteristics

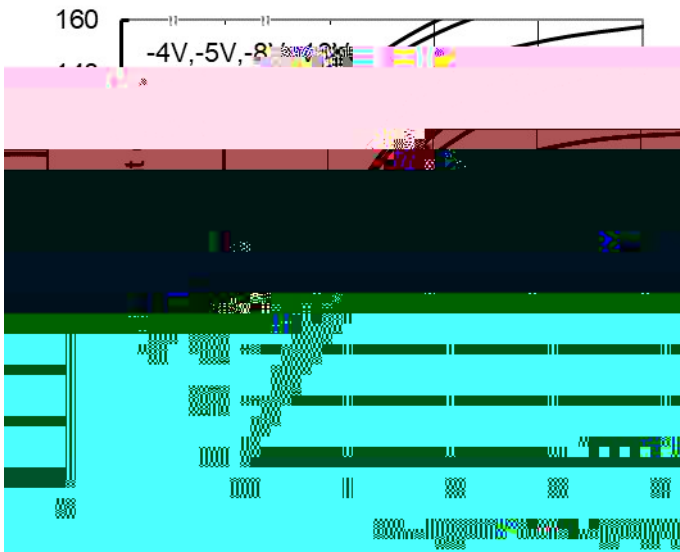

Figure 1. Output Characteristics

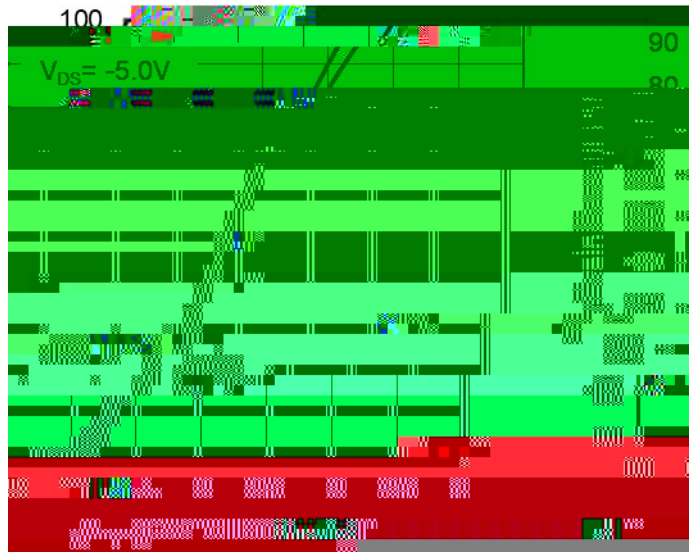

Figure 2. Transfer Characteristics

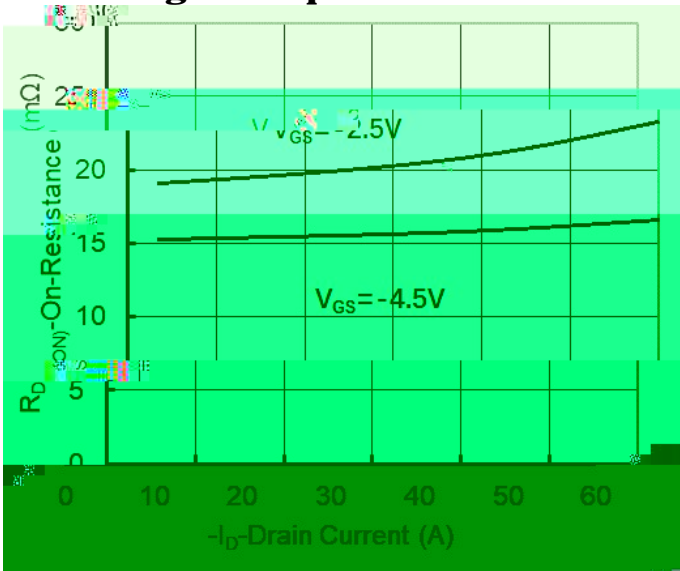

Figure 3. On-Resistance vs. Drain Current and Gate Voltage

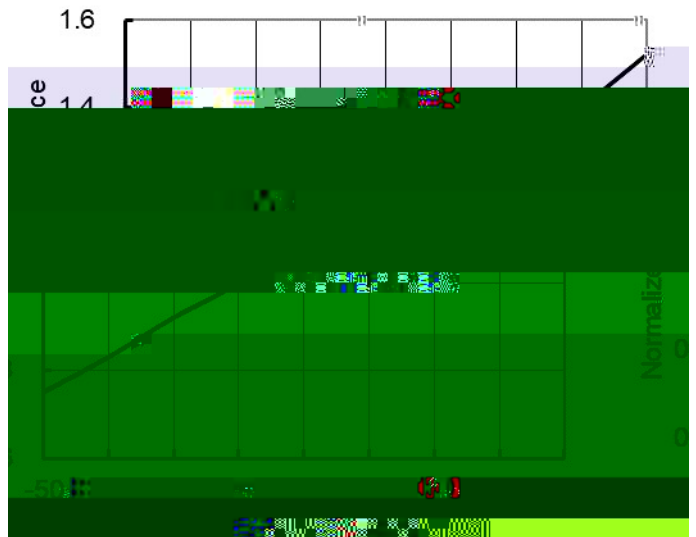

Figure 4. On-Resistance vs. Junction Temperature

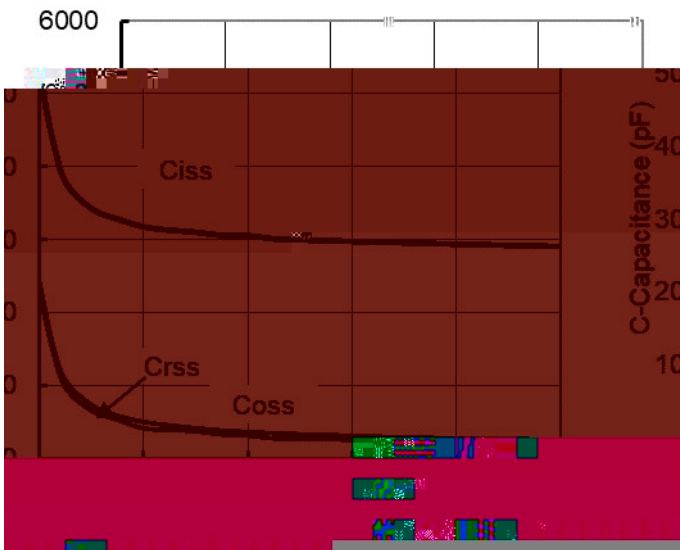

Figure 5. Capacitance Characteristics

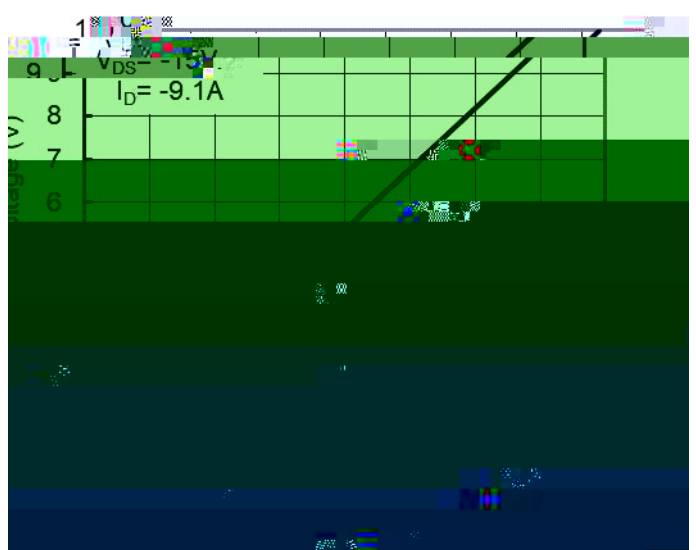
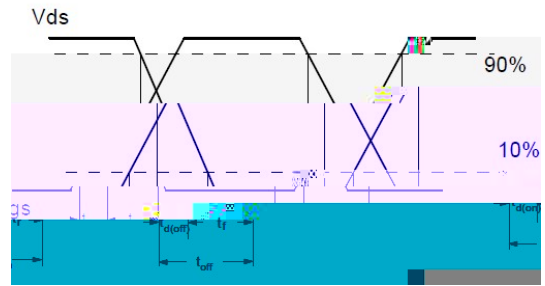
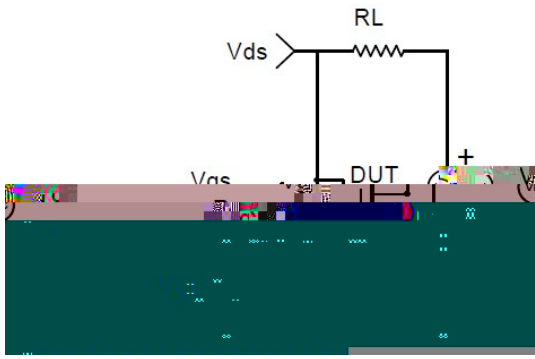
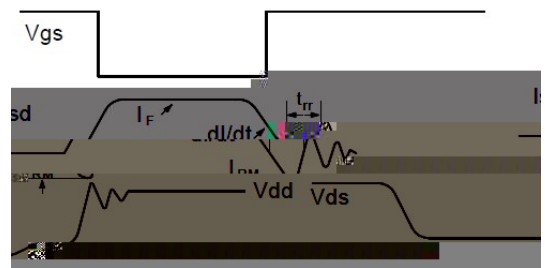
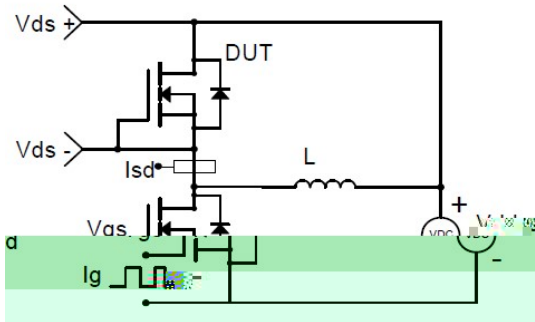

Figure 6. Gate Charge



Resistive Switching Test Circuit & Waveforms





YJL10P02AL

SOF-23 3L Package information

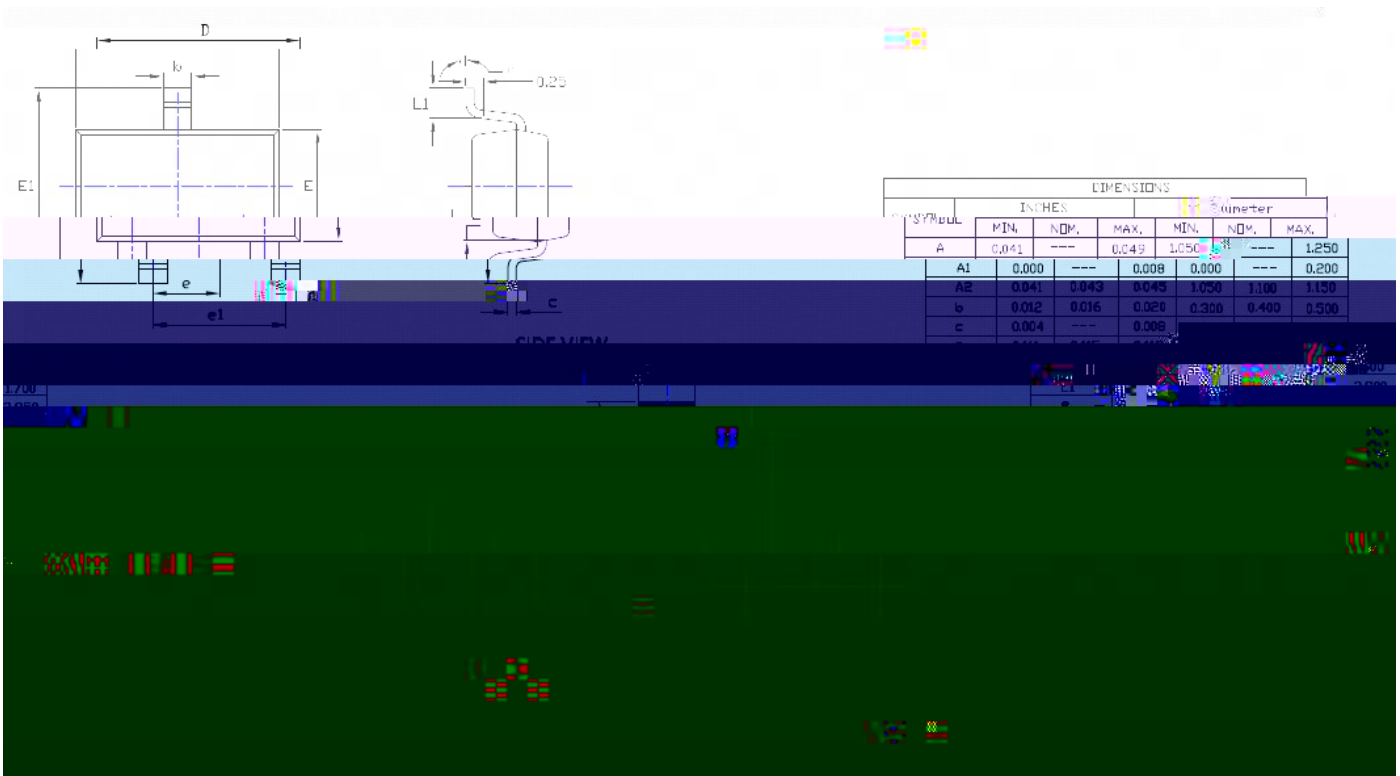



YJL10P02AL

Disclaimer
