

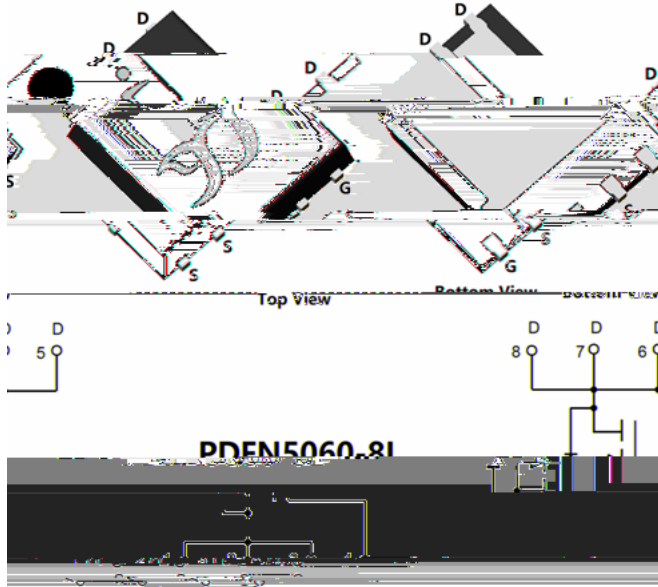

# N-Channel Enhancement Mode Field Effect Transistor



## Product Summary

$V_{DS}$	40V
$I_D$	110A
$R_{DS(ON)}$ ( at $V_{GS}=10V$ )	3.8m
100% EAS Tested	
100% $V_{DS}$ Tested	

## General Description

- Split Gate Trench MOSFET technology
- Excellent package for heat dissipation
- High density cell design for low  $R_{DS(ON)}$
- Moisture Sensitivity Level 1
- Epoxy Meets UL 94 V-0 Flammability Rating
- Halogen Free
- Part no. ~~25~~ unless otherwise noted)

Parameter	Symbol	Limit	Unit
Drain-source Voltage	$V_{DS}$	40	V A

Continuous Drain Current (Note 1,3)	Steady-State	$T_A=100$	14		
		$T_C=25$			110
		$T_C=100$			77
Pulsed Drain Current	$T_C=25, t_p=100\mu s$		$I_{DM}$	400	A
Avalanche energy	$V_G=10V, R_G=25, L=3mH, I_{AS}=13.5A$		EAS	273.3	mJ
Total Power Dissipation (Note 1,2)	Steady-State	$T_A=25$	2.7	W	
		$T_A=100$			1.3
Total Power Dissipation (Note 1,3)	Steady-State	$T_C=25$	83		
		$T_C=100$			41
Junction and Storage Temperature Range			$T_J, T_{STG}$	-55 +175	

## Thermal resistance

Parameter	Symbol	Typ	Max	Units
Thermal Resistance Junction-to-Ambient (Note 2)	$R_{JA}$	45	55	/W
Thermal Resistance Junction-to-Case	$R_{JC}$	1.5	1.8	

## Ordering Information (Example)

PREFERRED P/N	PACKING CODE	Marking	MINIMUM PACKAGE(pcs)	INNER BOX QUANTITY(pcs)	OUTER CARTON QUANTITY(pcs)	DELIVERY MODE
YJG3D8G04HHQ	F1	YJG3D8G04H	5000	10000	100000	13" reel



# YJG3D8G04HHQ

## Electrical Characteristics ( $T_J=25$ unless otherwise noted)

Parameter	Symbol	Conditions	Min	Typ	Max
-----------	--------	------------	-----	-----	-----



Typical Electrical and Thermal Characteristics Diagrams

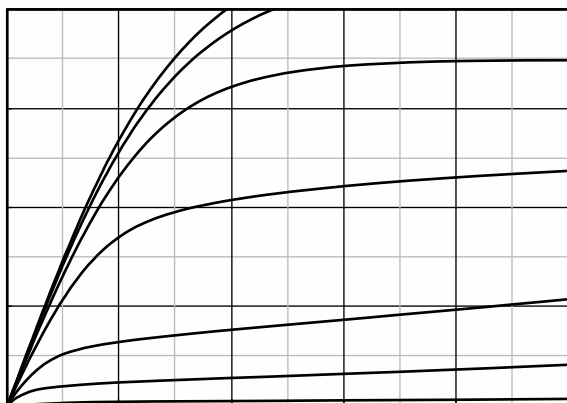



# YJG3D8G04HHQ

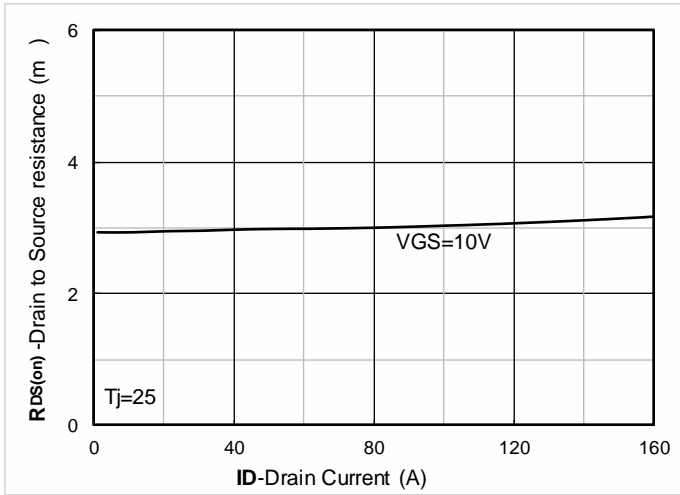

Figure 7. RDS(on) VS Drain Current

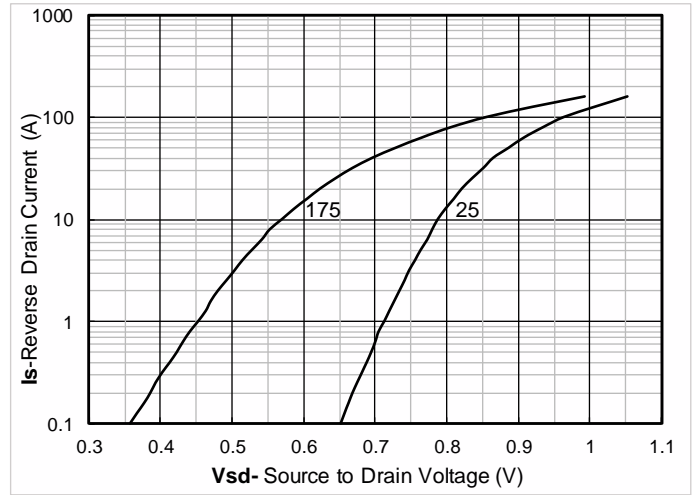
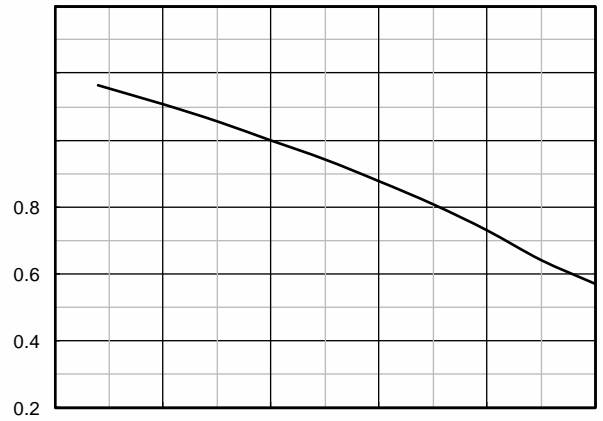
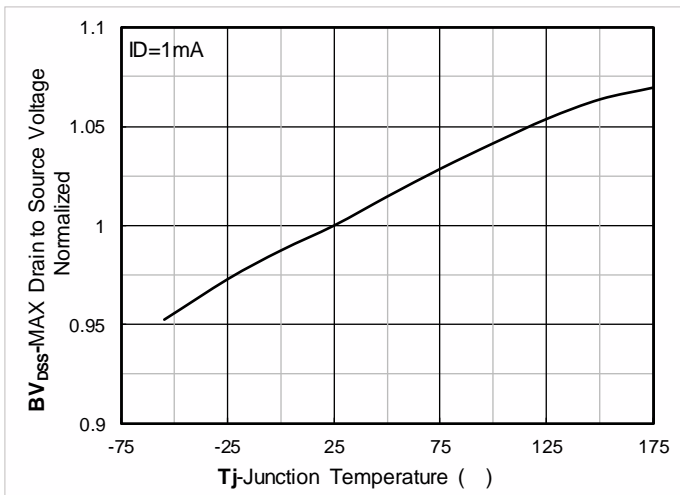
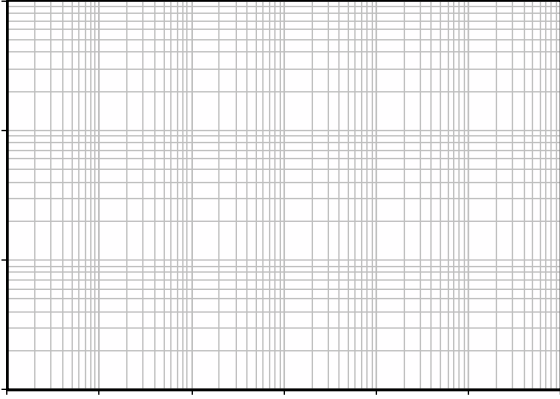

Figure 8. Forward characteristics of reverse diode







# YJG3D8G04HHQ

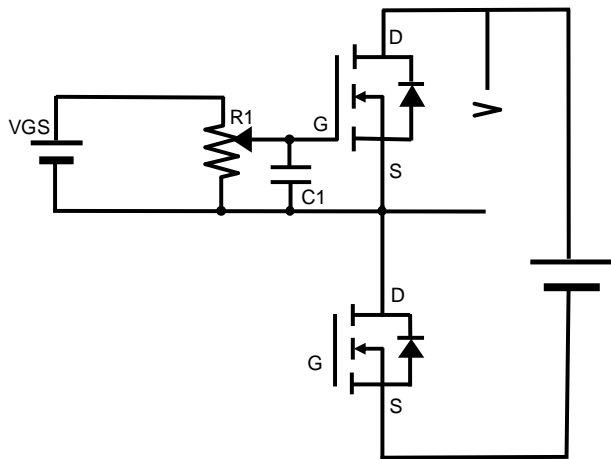



PDFN5060-8L-B-1.1mm Package information



Note:

1. Controlling dimension: in millimeters.
2. General tolerance:  $\pm 0.10\text{mm}$ .
3. The pad layout is for reference purposes only.

